

## Uptake of Silver From Large Silver Deposits on Biotic and Abiotic Components of the Closest Lothic System: Felent Stream, Turkey

Cem Tokatli<sup>1\*</sup>, Arzu Çiçek<sup>2</sup>, Esengül Köse<sup>3</sup> and Özgür Emiroğlu<sup>4</sup>

<sup>1</sup>Department of Laboratory Technology, Ipsala Vocational School, Trakya University, Ipsala / Edirne, Turkey

<sup>2</sup>Applied Environmental Research Centre, Anadolu University, Eskişehir, Turkey

<sup>3</sup>Department of Environmental Protection and Control, Eskişehir Vocational School, Eskişehir Osmangazi University, Eskişehir, Turkey

<sup>4</sup>Department of Biology, Faculty of Science, Eskişehir Osmangazi University, Eskişehir, Turkey

**Abstract.-** In the present study, water, sediment, diatom (epipellic), plant (*Lemma trisulca*), benthos (*Gammarus* sp. and *Hirudo* sp.) and fish samples (*Alburnus escherichii* and *Gobio sakaryaensis*) were collected from Felent Stream (closest lothic system to an important silver mine of Turkey) to determine the natural and anthropogenic effects. Cluster Analysis, Boxplot Deviation Diagrams and One Way ANOVA Test were applied to evaluate the data. Extreme silver contaminations were detected both in biotic and abiotic components of Köprüören Village. The highest silver level was recorded as 7.98 mg/kg in sediment of stream in spring season. Significant increases of silver levels were determined in spring and autumn seasons in water of entire basin. Silver bioaccumulations in tissues of *A. escherichii* and *G. sakaryaensis* followed the order: liver > gonad > gill > muscle. Significant differences were found in *Gammarus* sp. (0.026 – 0.234 mg/kg) and *L. trisulca* (0.009 – 0.206 mg/kg) collected from uncontaminated source of stream and Köprüören Village (contaminated) and in *Hirudo* sp. (under the detection limit – 0.05 mg/kg) collected from source of stream and solid waste storage area. Also silver bioaccumulations in epipellic diatom frustules of Yoncalı Village (after discharge of mine) were significantly higher than uncontaminated stations (an average of 7 times). It was also found that solid waste disposal site of Kütahya Province was an important source of silver pollution whereas Enne Dam Lake was a significant barrier for silver accumulation and biomagnification downstream of basin.

**Keywords:** Felent Stream, silver, abiotic factor, biotic factor, silver bioaccumulation.

### INTRODUCTION

Silver is a white, ductile and rare but naturally occurring metal in the pure form and often found deposited as a mineral ore in association with other elements (EPA, 1980). The global biogeochemical movements of silver are characterized by releases to the atmosphere, water, and land by natural and anthropogenic sources, long – range transport of fine particles in the atmosphere, wet and dry deposition, and sorption to soils and sediments (PHS, 1990). Silver is usually found in extremely low concentrations in natural waters because of its low crustal abundance and low mobility in water and also large industrial losses to the aquatic environment are probably infrequent because of its economic value as a recoverable resource (EPA, 1980; Nebeker *et al.*, 1983). But silver is of concern in various aquatic ecosystems

because of the severity of silver contamination in the water, sediment and biota (Rivera-Duarte and Flegal, 1993).

Felent Stream, which has a Dam Lake (Enne Dam Lake) on the watershed boundaries, is one of the most important branches of Porsuk Stream (Sakarya River Basin). It is used for purposes such as irrigation water, industrial water supply, receiving environment for domestic wastes and fishing activities carrying on especially Enne Dam Lake. In addition to the geologic structure of the Felent Stream Basin, silver mining facility is the most important source of silver for the region. It is the only mine in Turkey that produces direct silver from ore and has 21.5 million ton reserves. Silver mining facility that covers 1% of world's and 45% of Turkey's silver production is located in the Gümüş Village 33 km northwest of Kütahya Province and approximately 2 km far away from Felent Stream ([www.etigumus.com.tr](http://www.etigumus.com.tr); [www.mta.gov.tr](http://www.mta.gov.tr)).

The aim of this study is to evaluate the effects of silver mining facility and geological structure on

\* Corresponding author: tokatlicem@gmail.com  
0030-9923/2013/0003-0701 \$ 8.00/0  
Copyright 2013 Zoological Society of Pakistan

the Felent Stream by determining Ag accumulations in abiotic (water and sediment) and biotic (*Gammarus* sp., *Lemna trisulca*, *Hirudo* sp., EPP diatom frustules and muscle, gonad, gill and liver tissues of two fishes, *Alburnus escherichii* and *Gobio sakaryaensis*) components of system and by using some statistical techniques.

## MATERIALS AND METHODS

### Study area and collection of samples

Felent Stream with length of 35 km and the average flow rate of 0.56 m<sup>3</sup>/s is the most important branch of Porsuk Stream and exposed to a significant inorganic pollution (Anonymous, 2006). The study area and selected stations on the Felent Stream are shown in Figure 1. Water and sediment samples were collected seasonally (except winter season) between March 2011 – September 2011.

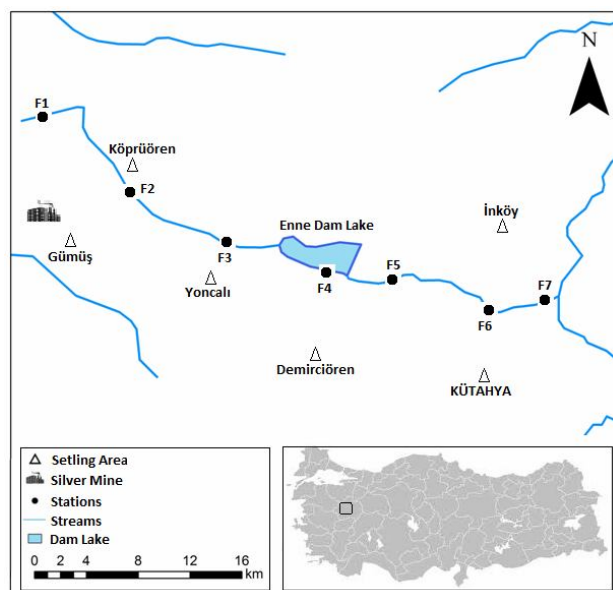

Fig. 1. Falent stream, Turkey, showing stations where sampling was done.

Water samples of one liter in volume were taken at each sampling point and was adjusted to pH 2 with 2 ml of HNO<sub>3</sub> being added to each, immediately. Sediments were collected from the stream, with sediment dipper and Ekman grab, taking small portions from the center of the dipper and grab with a polyethylene spoon to avoid

contamination by metallic parts of the grab.

All biotic materials were collected during spring season from the most appropriate stations to determine the regional differences of silver bioaccumulation. Fish samples were collected by electroshock formed by the modification Honda generator (EM1000F) from upstream of basin (from F2, F3 stations and before Dam Lake), which were the best appropriate areas with the structure of bottom stream, flow rate and method of electroshocker. Some characteristics of fishes are given in Table I. *Gammarus* sp. and *Hirudo* sp. samples were collected by benthos dipper and *L. trisulca* samples were collected directly by hand. EPP diatom samples were collected from above the sediment by using a glass pipe (Round, 1981). All the biotic samples were collected sufficient amounts to silver analysis (0.25 g dry weigh) and transported to iceboxes in the laboratory for chemical analysis.

Table I.- Characteristics of fishes, collected from silver-contaminated parts of the basin.

Fish sample	Weight (g)	Length (mm)		
		Standard	Fork	Total
<i>Alburnus escherichii</i> (n=3)				
Minimum	11.00	86.00	95.00	105.00
Maximum	17.00	105.00	114.00	125.00
Mean	13.33	93.67	103.00	113.33
SD	3.21	10.02	9.85	10.41
<i>Gobio sakaryaensis</i> (n=7)				
Minimum	8.00	83.00	90.00	97.00
Maximum	26.00	105.00	119.00	127.00
Mean	17.71	95.86	107.57	115.71
SD	6.16	8.65	10.92	12.30

### Chemical analysis

The diatoms were cleaned with sulfuric and nitric acid for the elimination of organic contents (Yıldırım, 1995). Fish samples were dissected by stainless-steel scissors, and muscle, liver, and gills were taken out. All biotic samples were dried for 24 h at 105°C. Sediment samples were dried for 3 h at 105°C for silver analyses. HClO<sub>4</sub>:HNO<sub>3</sub> (1:3) were added in all biotic and sediment samples (0.25 g) and placed in pyrex reactors of a CEM Mars Xpress 5 microwave digestion unit. Samples were mineralized at 200°C for thirty minutes. Afterwards,

the samples were filtered in such a way as to make their volumes to 100 ml with ultra-pure distilled water and used for determination of silver contents by Inductively Coupled Plasma-Optic Emission Spectrophotometric (Varian 720 ES) method. The element analyses were recorded as means triplicate measurements and the wavelength used for silver analysis was 328.068 nm (ASTM, 1985; APHA, 1992; EPA, 1998, 2001).

#### Statistical analysis

Cluster analysis and Boxplot Deviation Diagrams were applied to the results by using the Past package program. One Way ANOVA Test was applied by using SPSS 17 package program.

## RESULTS

Table II shows the silver accumulation in water, sediment and biotic factors (*Gammarus* sp., *L. trisulca*, *Hirudo* sp., EPP diatom frustules, *A. escherichii* and *G. sakaryaensis*) of Felent Stream. One Way ANOVA Test was used to compare the silver concentrations of different stations.

Seasonal variations in silver levels in water and sediment of Felent Stream are given in Figure 2. The highest silver level (0.01 mg/L) in water was found in station F2 during autumn and the lowest silver level (0.004 mg/L) in water was detected in F4 station during summer. The highest silver level (7.98 mg/kg) was detected in sediment of F2 station during spring and the lowest level (0.15 mg/kg) was found in F7 station during summer.

One Way ANOVA Test showed that there was no statistically significant difference in silver concentrations of water from different stations, though significant differences were detected in silver concentrations of sediments ( $p < 0.05$ ) between F2 and F4, F5 and F7 stations.

Silver bioaccumulations in different organs of *A. escherichii* and *G. sakaryaensis* followed the order: liver > gonad > gill > muscle. Silver levels of muscle tissues in the two fish species were under the detection limit, whereas liver accumulated 0.72 mg/kg silver in *G. sakaryaensis*.

Significant station differences were determined in terms of silver bioaccumulation levels in *Gammarus* sp. (0.03–0.23 mg/kg) and *L. trisulca*

(0.01–0.21 mg/kg) collected from F1 and F2 stations and in *Hirudo* sp. (under the detection limit – 0.05 mg/kg) collected from F1 and F6 stations.

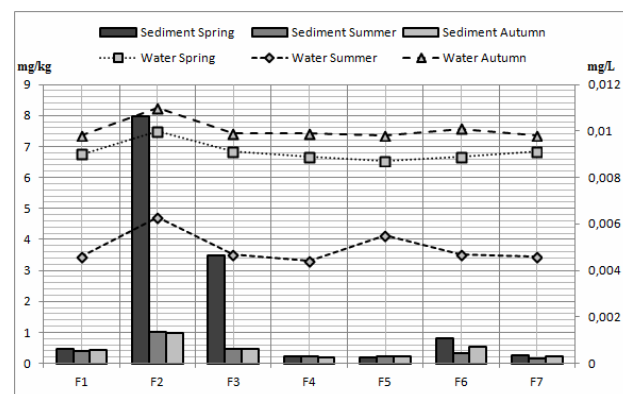

Fig. 2. Silver levels in water and sediment of Felent stream during spring, summer and autumn seasons.

The silver accumulation in biotic components in the upstream (before the Enne Dam Lake), followed the gradation *G. sakaryaensis* > EPP diatom frustules > *Gammarus* sp. > *L. trisulca* > *A. escherichii*, whereas in the downstream (after the Enne Dam Lake), it followed the order EPP diatom frustules > *Hirudo* sp.

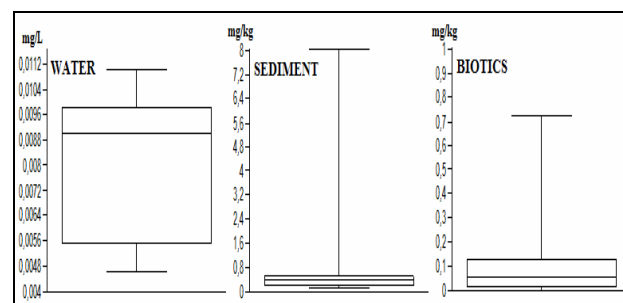

Fig. 3. Boxplot deviation diagrams showing silver levels in water, sediment and biotic components of Felent stream.

Figure 3 is a Boxplot diagram which shows the deviation in silver accumulations in abiotic and biotic components of Felent Stream. The silver content of water showed significant deviations mainly because of seasonal differences of silver concentrations in water. Also median value of Ag levels in water was closer to the Q3 than Q1 and

**Table II.- Silver accumulation in water ( $\mu\text{g/L} \pm\text{SD}$ ), sediment ( $\text{mg/kg} \pm\text{SD}$ ) and biotic components ( $\text{mg/kg} \pm\text{SD}$ ) collected from seven different stations of Felent Stream.**

St.	Water*	Sediment*	Gammarus sp.		Lemna trisulca	Hirudo sp.	EPP diatom frustules		Alburnus escherichii			Gobio sakaryensis		
			sp.	sp.			Muscle	Gonad	Gill	Liver	Muscle	Gonad	Gill	Liver
F1	7.8±2.8 <sup>a</sup>	0.43±0.04 <sup>ab</sup>	0.03±0.01	0.01±0.002	0.01±0.002	UDL	0.07±0.01	UDL	0.07±0.01	0.02±0.003	0.05±0.005	0.06±0.002	0.05±0.003	0.72±0.05
F2	9.1±2.4 <sup>a</sup>	3.33±4.027 <sup>a</sup>	0.23±0.01	0.21±0.01	0.21±0.01		0.34±0.03	UDL	0.01	0.003	0.005	0.002	0.003	0.05
F3	7.9±2.8 <sup>a</sup>	1.46±1.74 <sup>ab</sup>					0.03±0.01							
F4	7.7±2.9 <sup>a</sup>	0.21±0.01 <sup>b</sup>												
F5	8.0±2.2 <sup>a</sup>	0.22±0.02 <sup>b</sup>												
F6	7.9±2.8 <sup>a</sup>	0.56±0.25 <sup>ab</sup>				0.05±0.01	0.13±0.05							
F7	7.8±2.8 <sup>a</sup>	0.21±0.05 <sup>b</sup>					0.04±0.01							

\* The values marked with different letters (a – b) in the same column are statistically different ( $p < 0.05$ ) ( $n=21$ ) St., Stations; SD, Standard deviation; UDL, Under the detection limit.

variations. Maximum silver level of sediment was extremely higher than Q3 value and significant deviations were determined in biotic components of Felent Stream in terms of different organism groups that live in different habitats and also different tissues of fishes.

Figure 4 shows Cluster Analysis based on silver accumulations in water and sediment of Felent Stream. The highest similarity was found between F4 and F5 stations (93%) and the lowest similarity was determined between F2 and F4 stations (12%). Stations F2 and F3 with higher silver contents, F1 and F6 with moderate silver contents, and F4, F5 and F7 with lower silver contents were observed.

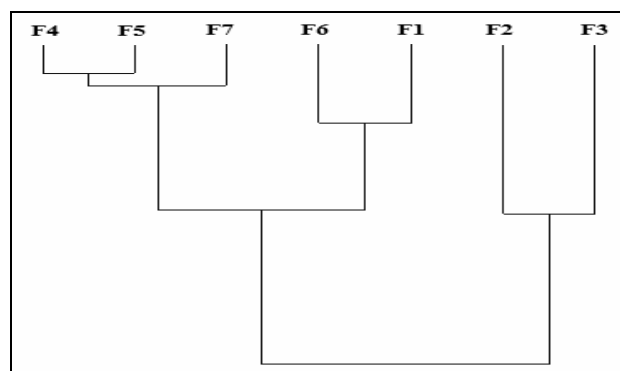

Fig. 4. Cluster analysis showing relationship of different sampling sections on the basis of accumulation of silver by water and sediment.

## DISCUSSION

Water chemistry is easily susceptible to instant changes, and sediments and biotic components of aquatic ecosystems are more useful to determine the long – term effects. Sediments of aquatic ecosystems that receive metals, mining wastes or sewage usually have higher silver concentrations than uncontaminated sediments and contaminated sediments usually include more than 0.1 mg/kg silver (Bryan and Langston, 1992). In the present study, silver accumulations in sediments of Felent Stream have exceeded this limit value specified by Bryan and Langston almost in all stations in all seasons. In fact silver level of sediment detected in F2 station during spring was

extremely higher (80x) than the limit value.

One of the highest recorded silver concentration in fresh water was 0.038 mg/L in the Colorado River at Loma, Colorado (downstream of an abandoned gold–copper–silver mine, an oil shale extraction plant, a gasoline and coke refinery and uranium processing facility (EPA, 1980). This recorded value is five times higher than Felent Stream water (average of all stations).

In the present study, silver concentration in water increased significantly during spring and autumn seasons. Rain washes silver compounds out of many soils so that it eventually moves into the surface and groundwater (ATSDR, 1990). In spring and autumn, more rainfall on Felent Stream Basin may explain the sudden rise of silver in water.

In a study performed in Emet Stream, silver accumulation of water were recorded as 0.00035 mg/L – 0.0014 mg/L and silver accumulations of sediment were recorded as 0.27 mg/kg – 0.73 mg/kg (Tokatlı *et al.*, 2013). In the present study, silver levels in water was 0.008 mg/L even in uncontaminated stations and 0.91 mg/kg in sediment which was significantly higher than the silver levels in water and sediment of Emet Stream Basin. The silver bioaccumulation in fishes of Emet Stream, especially caught from downstream, was higher than that of the present study (Tokatlı *et al.*, 2013).

Although silver concentrations of water detected in F2 station (where the Silver Mine wastes are discharged to the system) were higher than in other stations during all seasons, any statistically significant difference between stations could not be found. The bioaccumulation in organisms, however, are better indicator of the inorganic pollution. Amphipods from the genus *Gammarus* are among the most frequently used organisms in ecotoxicological testing and bioindication especially *in situ* conditions and *L. trisulca* is an aquatic plant with an excellent potential for toxicological studies (Adam *et al.*, 2010; Huebert *et al.*, 1993). According to data observed, extreme differences were identified in terms of Ag bioaccumulations of *Gammarus* sp. and *L. trisulca* collected from different stations. Silver levels of *Gammarus* sp. and *L. trisulca* collected from F2 station were 9 times and 22 times, respectively, higher than the same taxa collected from F1 station. It was also

determined that silver concentrations of sediment detected in F2 station extremely higher than other stations in all seasons and the differences were statistically significant ( $p < 0.05$ ).

Diatoms especially epipelics are directly associated with sediment and according to Tokatlı *et al.* (2011), EPP diatom frustules are useful indicator organisms for element accumulation. F3 station that clustered with F2 was located at the downside of mine discharge area. Silver levels in sediment and EPP diatom frustules of F3 station were significantly higher than other stations (except F2 station). Silver bioaccumulations in EPP diatom frustules of F3 station were on the average 5 times higher than F1; 11 times higher than F4; 3 times higher than F6; and 8 times higher than those of F7 stations.

F1 station that was located quite close to the source of Felent Stream and away from pollution and any waste discharge formed a cluster with F6 station, where was located quite close to the solid waste disposal site of Kütahya Province. These results reflect that, geological structure especially around the upstream basin is a significant factor on silver accumulations in Felent Stream and solid waste disposal site of Kütahya Province is also an important factor on silver pollution. Although silver contents of abiotic components of these stations were similar, silver bioaccumulation levels of *Hirudo* sp. collected from F6 station (0.054 mg/kg) were significantly higher than the same taxa collected from F1 station. These results could reflect that, organisms are affected by point sources more than geological structure.

F4, F5 and F7 stations also formed a cluster according to silver levels of abiotic components. F4 station was located at the Enne Dam Lake and water – sediment samples were collected from littoral zone from a close area to the output of Dam Lake. F5 station was located on the Felent Stream after from the output of Dam Lake. According to data, it was determined that Felent Stream has left a large part of silver contents to the Enne Dam Lake and detected quite high similarity between F7 station (the last station before falling Porsuk Stream) and F4 – F5 stations show that solid waste disposal site of Kütahya Province is not a critical risk factor for the system as much as silver mine and geological

structure of upstream basin.

*A. escherichii* and *G. sakaryaensis* are endemic for Turkey and it was stated that the distribution area of *A. escherichii* is Sakarya River drainage and Kızılırmak River (Turkey) and the distribution area of *G. sakaryaensis* is Tozman Stream and Sakarya River (Turkey) ([www.fishbase.org/summary/Alburnus-escherichii.html](http://www.fishbase.org/summary/Alburnus-escherichii.html);/ [www.fishbase.org/summary/Gobio-sakaryaensis.html](http://www.fishbase.org/summary/Gobio-sakaryaensis.html)). Both these fishes are benthopelagic, so they clearly reflect the accumulation of sediment. The metals (non – lethal concentrations) accumulate in metabolically active tissues (Kargin and Erdem, 1992). According to silver bioaccumulation results of fish samples collected from upstream, highest silver levels were observed in liver tissues of two fish species in parallel. The higher accumulation in liver may alter the levels of various biochemical parameters in these tissues. This may also cause severe liver damage and a primary impact on the health of fish (Mayers and Hendricks, 1984; Ferguson, 1989). Freshwater fishes are the most sensitive vertebrates to dissolved silver, although relatively tolerant species exist. In fish toxicity tests with 22 metals and metalloids, silver was the most toxic tested element as judged by acute LC<sub>50</sub> values (Birge and Zuiderveen, 1995; Ratte, 1999). Therefore, silver pollution of region could become an important limiting factor for fish populations in the future.

To conclude silver mine and geological structure of upstream basin adversely effect the system and they are the main risk factors for the Felent Stream and aquatic life. Solid waste disposal site of Kütahya Province located on the downstream of watershed is also a significant silver pollution factor for the system and Enne Dam Lake acts as a significant barrier for the downstream of Felent Stream both for abiotic and biotic components in terms of silver accumulations and biomagnifications.

#### ACKNOWLEDGEMENT

This investigation has been supported by the project numbered as 1101F018 accepted by Commission of Scientific Research Projects of Anadolu University and the authors would like to thank Fatma AKBIYIK for her contributions.

#### REFERENCES

- ADAM, O., DEGIORGI, F., CRINI, G. AND BADOT, P.M., 2010. High sensitivity of *Gammarus* sp. juveniles to Deltamethrin: outcomes for risk assessment. *Ecotoxicol. Environ. Saf.*, **73**:1402-1407.
- ANONYMOUS, 2006. *Kütahya İl Çevre Durum Raporu*. T.C. Kütahya Valiliği İl Çevre ve Orman Müdürlüğü, 324syf.
- APHA, 1992. *Standard methods for the examination of water and wastewater* (eds. A.E. Greenberg, L.S. Clesceri and A.D. Eato.), American Public Health Association, 18th ed., Washington, U.S.A.
- ASTM, 1985. *Preparation of biological samples for inorganic chemical analysis 1*, Annual Book of ASTM Standards, D-19, pp. 740- 747.
- ATSDR, 1990. *Toxicological profile for silver*. Agency for Toxic Substances and Disease Registry, U.S. Department of Health and Human Services, Atlanta, GA.
- BIRGE, W.J. AND ZUIDERVEEN, J.A., 1995. The comparative toxicity of silver to aquatic biota. In: *Transport, fate and effects of silver in the environment* (eds. A. W. Andren and T. W. Bober). Abstracts of 3rd international conference, 6-9 August 1995, Washington, D.C. University of Wisconsin Sea Grant Institute, Madison.
- BRYAN, G.W. AND LANGSTON, W.J., 1992. Bioavailability, accumulation and effects of heavy metals in sediments with special reference to United Kingdom estuaries: a review. *Environ. Pollut.*, **76**:89-131.
- ENVIRONMENTAL PROTECTION AGENCY (EPA), 1980. *Ambient water quality criteria for silver*. U.S. Environmental Protection Agency Report 440/5-80-071. 212 pp.
- ENVIRONMENTAL PROTECTION AGENCY (EPA) METHOD 3051. 1998. *Microwave assisted acid digestion of sediments, sludges, soils and oils*.
- ENVIRONMENTAL PROTECTION AGENCY (EPA) METHOD 200.7., 2001. *Determination of metals and trace elements in water and wastes by inductively coupled plasma-atomic emission spectrometry*.
- FERGUSON, H.W., 1989. *Systematic pathology of fish*. Iowa State University Press. Ames. IA.
- HUEBERT, D.B. AND GORHAM, P.R., 1993. Biohasic mineral nutrition of the submered aquatic macrophyte *Potamogeton pectinatus* L. *Aqual. Bot.*, **16**: 269–284.
- KARGIN, E. AND ERDEM, C., 1992. Bakır-Çinko Etkileşiminde *Tilapia nilotica*'nın karaciğer, kas ve solungaç dokularındaki Metal Birikimi. *Doğa Tr. J. Zool.*, **16**: 343-348.
- MAYERS, T.R. AND HENDRICKS, J.D., 1984. Histopathology. In: *Fundamental of aquatic toxicology* (eds. G.M. Rand and S.R. Petrocelli), Hemisphere, Washington DC.

- NEBEKER, A. V., MCAULIFFE, C. K., MSHAR, R. AND STEVENS, D. G., 1983. Toxicity of silver to steelhead and rainbow trout, fathead minnows and *Daphnia magna*. *Environ. Toxicol. Chem.*, **2**:95-104.
- RATTE, H.T., 1999. Bioaccumulation and toxicity of silver compounds: A review. *Environ. Toxicol. Chem.*, **18**: 89–108.
- RIVERA-DUARTE, I. AND FLEGAL, A. R., 1993. Pore water fluxes of silver in estuaries. In: *Proceedings of the first international conference on transport, fate, and effects of silver in the environment* (eds. A. W. Andren, T. W. Bober, E. A. Crecelius, J. R. Kramer, S. N. Luoma, J. H. Rodgers, and A. Sodergren). University of Wisconsin Sea Grant Institute, Madison. pp. 37-39
- PUBLIC HEALTH SERVICE (PHS), 1990. *Toxicological profile for silver*. Agency for Toxic Substances and Disease Registry TP-90-24. 145 pp.
- ROUND, F.E., 1981. *The ecology of algae*. Cambridge University Press, Cambridge, pp. 653.
- TOKATLI, C., ARSLAN, N., ÇIÇEK, A., KÖSE, E., EMİROĞLU, Ö. AND DAYIOĞLU, H., 2013. Effect of silver on aquatic ecosystems of Emet Stream Basin, Turkey. *Pakistan J. Zool.*, **45**: 521-529.
- TOKATLI, C., KÖSE, E., ARSLAN, N., ÇIÇEK, A. AND UYSAL, K., 2011. Porsuk baraj gölü epipelik diyatome frustullerinde makro ve mikro element konsantrasyonları. *Tarım Bilimleri Araştırma Dergisi* **4**:1-6.
- YILDIRIM, V., 1995. Hazar Gölü (Gölcük) Sivrice İlçesi Tarafındaki Koy'un Temiz ve Kirliliği Kesimlerinde Fitoplankton ve Bentik Alg Florasının Araştırılması. Doktora Tezi. Fırat Üniversitesi Fen Bilimleri Enstitüsü, Elazığ.
- <http://www.etigumus.com.tr>  
<http://www.fishbase.org/summary/Alburnus-escherichii.html>  
<http://www.fishbase.org/summary/Gobio-sakaryaensis.html>  
<http://www.mta.gov.tr>

(Received 16 February 2013, revised 18 April 2013)